

MODEL RLY6/RLY6A - SINGLE PHASE DIN RAIL MOUNT SOLID STATE RELAY



- INTEGRATED HEAT SINK
- OPTICALLY ISOLATED
- SOLID STATE SWITCHING
- SINGLE PHASE OUTPUT RATING: 25 A (RLY6) or 40 A (RLY6A)
- SWITCHING: 24 TO 660 VAC
- CONTROL SIGNAL: 4 TO 32 VDC
- ZERO VOLTAGE TURN-ON
- MOUNTS ON DIN RAIL OR DIRECTLY TO PANEL
- 4000 VOLT ISOLATION
- BUILT-IN SNUBBER
- LED "ON" INDICATOR
- CAGE CLAMP TERMINATIONS



UL Recognized Component,
 File #E191578



LR 702877

GENERAL DESCRIPTION

The RLY60000 is a solid state relay that switches load currents up to 25 A; the RLY6A000 switches load currents up to 40 A. These units feature a zero voltage turn-on detector to minimize radiated RFI when switching. An internal snubber guards against false triggering of the output related to high dv/dt applications. A low level DC control signal of 4 to 32 VDC is all that is needed for the switching operation. These units, highlighted by the inverse-parallel SCR output, provide a greatly increased operational life over mechanical relays by avoiding the usual relay contact problems such as: arcing, bouncing, and mechanical failure.

The RLY6/RLY6A can be directly controlled by logic/SSR drive output or sourcing output of Red Lion Controls products.

SAFETY SUMMARY

All safety related regulations, local codes and instructions that appear in the literature or on equipment must be observed to ensure personal safety and to prevent damage to either the instrument or equipment connected to it. If equipment is used in a manner not specified by the manufacturer, the protection provided by the equipment may be impaired.

Do not use this unit to directly command motors, valves, or other actuators not equipped with safeguards. To do so, can be potentially harmful to persons or equipment in the event of a fault to the unit.

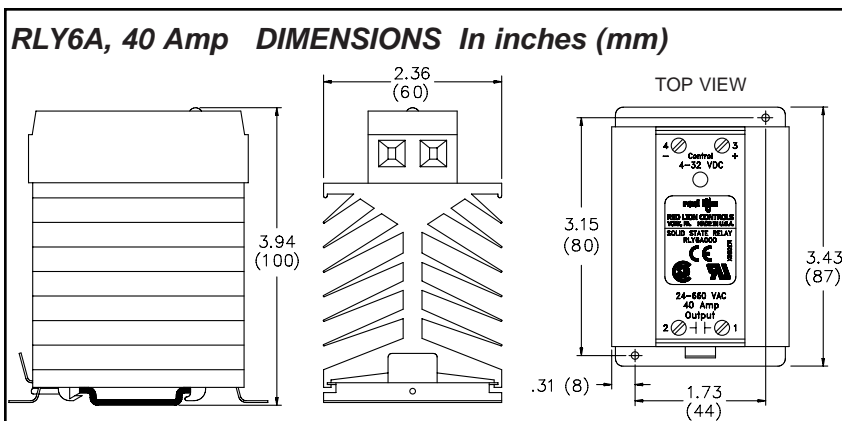
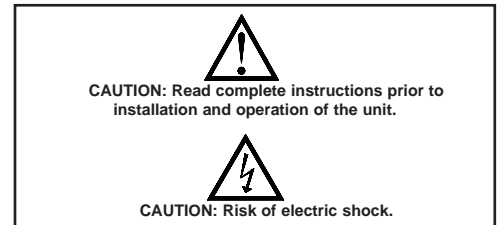
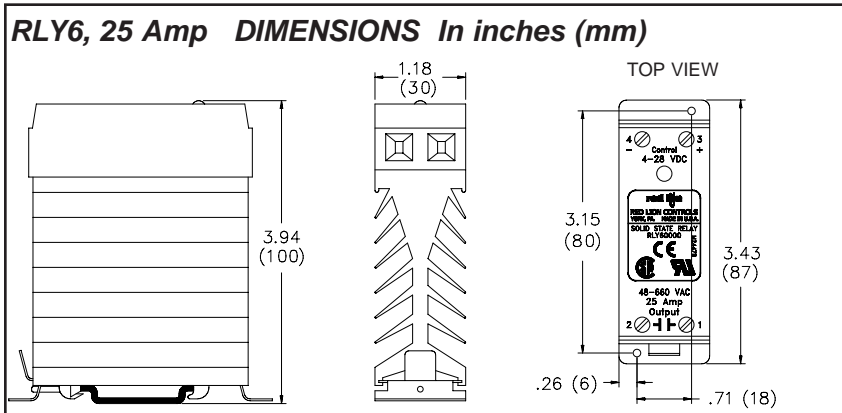

SPECIFICATIONS

OUTPUT SPECIFICATIONS

1. OPERATING VOLTAGE RANGE: 24 to 660 VAC
2. OPERATING FREQUENCY RANGE: 47 to 63 Hz
3. MAXIMUM CONTINUOUS LOAD CURRENT:
 (See Safe Operating Conditions)

RLY6: 25 A_{RMS}

RLY6A: 40 A_{RMS}

4. SURGE CURRENT:

RLY6:

Non-Repetitive 1 Cycle: 250 A_{PEAK}

Non-Repetitive 1 Second: 100 A_{PEAK}

RLY6A:

Non-Repetitive 1 Cycle: 250 A_{PEAK}

Non-Repetitive 1 Second: 150 A_{PEAK}

5. MIN. LOAD CURRENT: 100 mA
6. LEAKAGE CURRENT @ V_{OUT} (Max.): 8 mA
7. OVER VOLTAGE RATING: 1400 PIV
8. VOLTAGE DROP @ I_{OUT}: 1.5 VAC
9. POWER DISSIPATION AT FULL LOAD:

RLY6: 25.0 Watts

RLY6A: 48.0 Watts

SPECIFICATIONS (Cont'd)

10. I^2T FUSING: 1035 A²S

(For Fusing Purposes, T = 8.3 msec.)

11. Dv/Dt @ V_{OUT} (Max.): 500 V/ μ sec

INPUT SPECIFICATIONS

- CONTROL VOLTAGE RANGE: 4 to 32 VDC
- TURN-ON VOLTAGE (MIN.): 4 VDC
- TURN-OFF VOLTAGE (MAX.): 1 VDC
- REVERSE VOLTAGE PROTECTION: -75 VDC
- INPUT CURRENT (MAX.): 8 mA

GENERAL SPECIFICATIONS

- ISOLATION (INPUT TO OUTPUT TO BASE): 4000 V_{RMS}
- CAPACITANCE INPUT TO OUTPUT: 3 pf
- OPERATING TEMPERATURE RANGE: -40°C to +80°C

SAFE OPERATING CONDITIONS

The relay must always operate within the "Safe Operating Area" of the Derating Curve Figure. Operations outside the Safe Operating Area will shorten the life of, or cause permanent damage to, the relay. The ambient temperature should be measured 1" (25 mm) below the relay (when mounted to a vertical surface) and with all of the associated equipment operating.

RLY6 25 A Derating Curve

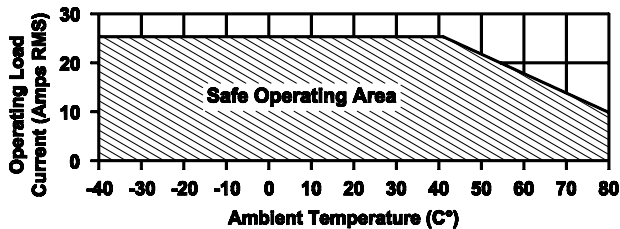

RLY6A 40 A Derating Curve

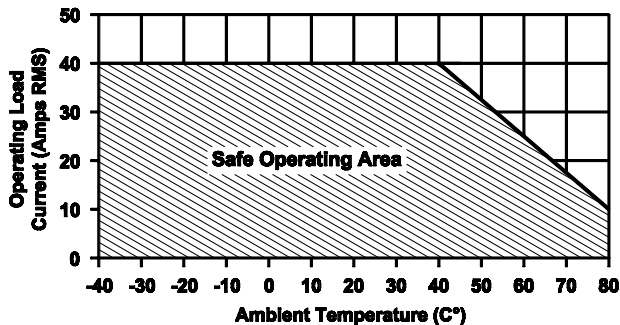

It is strongly recommended that a 0.18" (4.6 mm) clearance is maintained on all four sides of the relay. If the relays are mounted against each other, then the end relays must be derated by additional 10% (of the Derating Curve) and the middle relays by 20%.

In small enclosures, adequate ventilation must be provided to assure proper safe operating temperature. Accumulation of dust and dirt on the heat sink fins will also affect heat dissipation. In extreme dust and dirt conditions, the relay must be derated by additional 20%.

SCHEMATIC

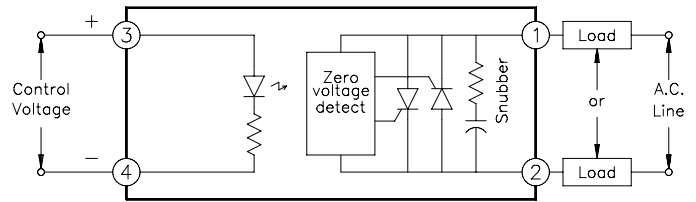

FUSING

Devices such as electromechanical circuit breakers and slow blow fuses cannot react quickly enough to protect this relay in a shorted condition. Fast "semiconductor fuses" with appropriate I^2T ratings are strongly recommended.

MECHANICAL INTERRUPT SWITCH

The off-state leakage current of the power unit is 8 mA maximum. The voltage level of the output will rise proportional to the resistance of the load due to this leakage current. Full line voltage can be measured when the output is connected to a high resistance load and the power unit is in the off-state.

A mechanical interrupt switch is recommended between both sides of the line voltage and the load. The switch should be opened when servicing any part of the output wiring. When measuring the off-state output voltage of the unit for correct operation, load the output of the RLY6/RLY6A with a small resistance (approximately 100 ohms).

WIRING GUIDELINES

The controlling device and the relay load should NEVER share the same power feed. It is recommended that this relay be installed as close as possible to the load to keep the power cable runs short. The control voltage can run over distances in excess of 200 feet with shielded cable. If using shielded cable, connect the shield to the minus "-" terminal of the control signal at one end only.

ORDERING INFORMATION

MODEL	DESCRIPTION	PART NUMBERS
RLY6	25 A Single Phase Din Rail Mount Solid State Relay	RLY60000
RLY6A	40 A Single Phase Din Rail Mount Solid State Relay	RLY6A000

LIMITED WARRANTY

The Company warrants the products it manufactures against defects in materials and workmanship for a period limited to one year from the date of shipment, provided the products have been stored, handled, installed, and used under proper conditions. The Company's liability under this limited warranty shall extend only to the repair or replacement of a defective product, at The Company's option. The Company disclaims all liability for any affirmation, promise or representation with respect to the products.

The customer agrees to hold Red Lion Controls harmless from, defend, and indemnify RLC against damages, claims, and expenses arising out of subsequent sales of RLC products or products containing components manufactured by RLC and based upon personal injuries, deaths, property damage, lost profits, and other matters which Buyer, its employees, or subcontractors are or may be to any extent liable, including without limitation penalties imposed by the Consumer Product Safety Act (P.L. 92-573) and liability imposed upon any person pursuant to the Magnuson-Moss Warranty Act (P.L. 93-637), as now in effect or as amended hereafter.

No warranties expressed or implied are created with respect to The Company's products except those expressly contained herein. The Customer acknowledges the disclaimers and limitations contained herein and relies on no other warranties or affirmations.

Red Lion Controls
20 Willow Springs Circle
York PA 17402
Tel +1 (717) 767-6511
Fax +1 (717) 764-0839

Red Lion Controls BV
Basicweg 11b
NL - 3821 BR Amersfoort
Tel +31 (0) 334 723 225
Fax +31 (0) 334 893 793

Red Lion Controls Asia
31, Kaki Bukit Road 3,
#06-04/05 TechLink
Singapore 417818
Tel +65 6744-6613
Fax +65 6743-3360